

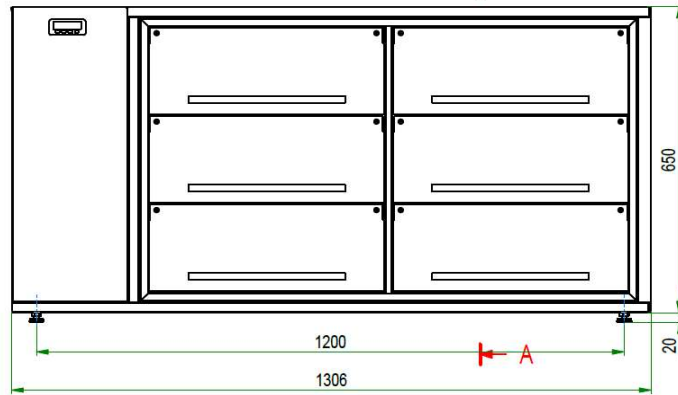

Model	BLOCK 1300	BLOCK 1300 Remote
Length (mm)	1302	1302
Width (mm)	619	619
Height (mm)	670	670
Display area (m2)	0,88	1,08
Temperature (°C)	+2/+10	+2/+10
Power (W)	220	220
Energy class	<b>C</b>	<b>C</b>
Cooling gas	R290	R290
Consumption (kWh/24h)	3,52	3,96
Voltage (V/Hz)	230/50	230/50
Weight (Kg)	100	123

- Double side glass
- Front side could be equipped with:
  - \* double tempered glass
  - \* double sliding doors
  - \* plexiglass hatches (2 or 3 levels)
  - \* wing door
- Rear sliding doors
- Tempered glass shelves
- LED lighting
- Static cooling, electronic control unit
- Automatic defrost and evaporation
- Operating conditions of +25 °C and 60 % ambient humidity

## BLOCK 1300

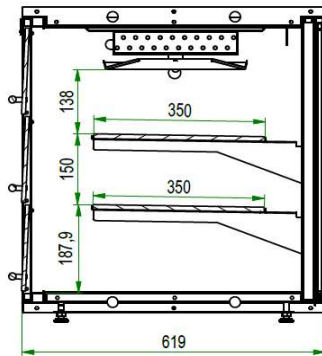

## BLOCK 1300 Remote

